

HC9 miniBOOSTER



HC9 version: 8 intensification factor

P_{IN}: 20 – 207 bar (inlet pressure)

P_H: 5,000 bar maximum (outlet pressure)

P_{RETURN}: As low as possible (return pressure to tank)

P_{OUTLET} = P_H = (P_{IN} - P_{Return}) I (intensification)

Mounting: Inline tube

Accessories: Pilot- operated dump valve available

A model = no dump valve

B model = with dump valve, up to 3,000 bar

Description

The HC9 is an ultra high- pressure unit which is capable of delivering up to 5,000 bar and 0.3 l/ min flow on the high- pressure end. Like other miniBOOSTER models, the HC9 raises supplied pressure to a higher outlet pressure and automatically compensates for consumption of oil to maintain the high pressure.

Adjustment of the outlet pressure is carried out by varying the supplied pressure. Relative to its flow capability, the HC9 is a compact unit weighing only 9.9 kg.

Flow rates

Intensification factor i	Approx. outlet flow l/ min	Max. inlet flow l/ min
6.2	4.0	20.0
8.2	3.3	20.0
9.5	3.0	20.0
11.0	2.5	20.0
13.0	2.0	20.0
16.0	1.5	20.0
20.0	0.8	20.0
25.0	0.3	20.0

Function

The basic operation is illustrated in the function diagram. Oil is fed through the directional valve CV to the IN port, flowing freely through the check valves KV1 and KV2 to the high- pressure side H. In this condition maximum flow through the booster is achieved giving a fast- forward function.

When pump pressure is reached on the high- pressure side H, valves KV1 and KV2 will close. The end pressure will be achieved by the oscillating pump unit OP. The unit will automatically stall when end pressure on the high- pressure side H is reached. If a pressure drop on the high- pressure side exists due to consumption or leakage, the OP valve will automatically operate to maintain the end pressure.

Function diagram

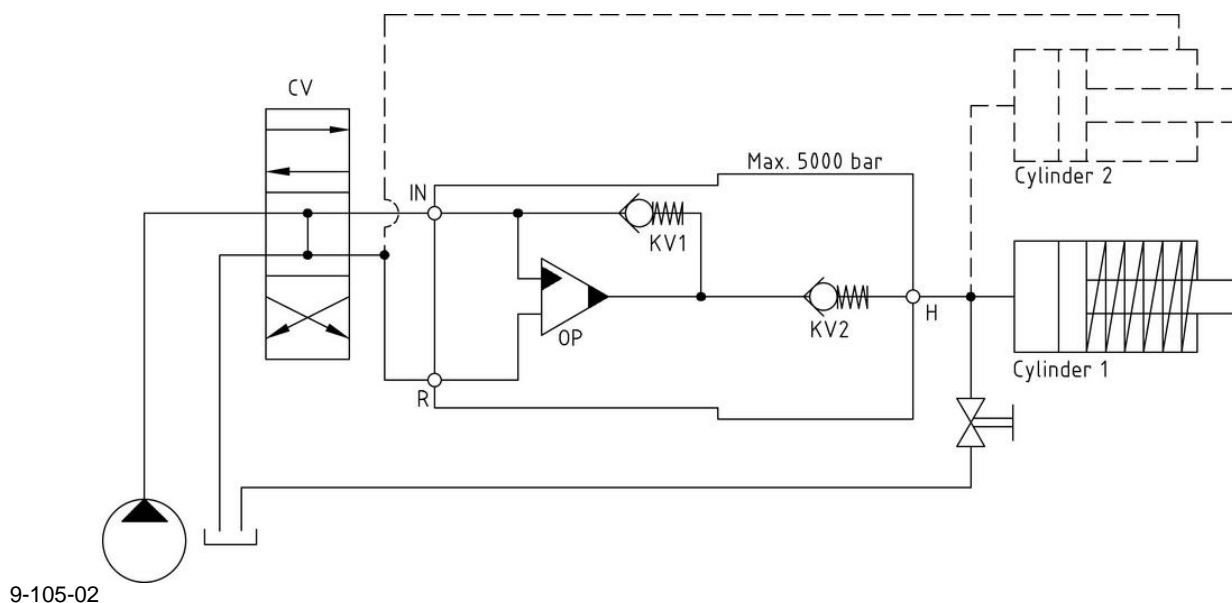

PDF- file: HC9 Function diagram 9-105-02

Dimension drawing



PDF- file: Dimension drawing 9-120-12

Connection types

Connection	IN / R
1	1/2" BSPP

Max. tightening torque BSPP

	IN / R
	1/2" BSPP
with steel washer	13.0 da/ Nm
with aluminium washer	–
with cutting edge	13.0 da/ Nm

High Pressure Plate

High pressure plate ordering codes and specifications can be seen from the table in the PDF- file below - please see:



High Pressure Plate connection possibilities: 8-900-12

Fluids and materials

Please see: General specifications

Ordering an HC9

Ordering example of an HC9 with $i = 25.0$, without DV and BSPP connections: HC9 - 25.0 - A - 1

Please note!

High- pressure plate ordering code - see table

Other high- pressure connections on request.

<i>Model</i>	<i>Intensification, i</i>	<i>Dump valve</i>	<i>Connections</i>
HC9	your selection...	your selection...	your selection...
	see flow rate table	A = (no) / A model	1
		B = (yes) / B model	