

HC7W miniBOOSTER



HC7W versions: 5 different intensification factors

P_{IN} : 20-207 bar (inlet pressure)

P_H : 2,000 bar maximum for media > 5 cSt (mm²/s)

P_H : 1,000 bar maximum for media < 5 cSt (mm²/s)

P_{RETURN} : As low as possible (return pressure to tank)

P_{OUTLET} : $P_H = (P_{IN} - P_{RETURN}) \times i$ (intensification)

Mounting: Inline tube

Accessories: Pilot-operated dump valve incorporated

A model = no dump valve

B model = with dump valve

G model = direct proportionally controlled

Material certificate on request.

Description

The HC7W is a very compact high-pressure unit capable of delivering pressure up to 2,000 bar weighing only 1.5 kg. It is ideal for use with very thin (low viscosity) medias. It is ideal for use in portable applications like on power packs.

The HC7W raises supplied pressure to a higher outlet pressure and automatically compensates for consumption of media to maintain the high pressure. Adjustment of the outlet pressure is carried out by varying the supplied pressure. With the choice of different high-pressure adapters, a variety of threads can be obtained from the M22x1.5 thread in the HP port.

Flow rates

Intensification factor i	Max. outlet flow l/ min	Max. inlet flow l/ min
5.0	1.6	14.0
6.6	1.3	13.0
9.0	0.9	13.0
13.0	0.6	12.0
20.0	0.3	12.0

Functions

The basic operation is illustrated in the function diagram. Media is fed through the directional valve CV to the IN port, flowing freely through the check valves KV1, KV2 and DV to the high- pressure side H. In this condition, maximum flow through the booster is achieved, giving a fast-forward function.

When pump pressure is reached on the high- pressure side H, valves KV1, KV2 and DV will close. The end pressure will be achieved by the oscillating pump unit OP. The unit will automatically stall when end pressure on the high- pressure side H is reached. If a pressure drop on the high- pressure side exists due to consumption or leakage, the OP valve will automatically operate to maintain the end pressure.

Function diagram

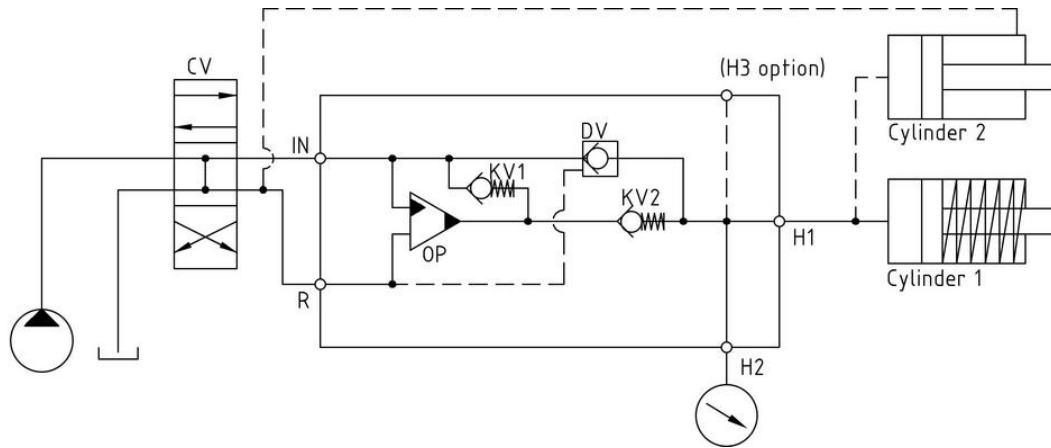

7-105-00



Function diagram 7-105-00

Dimensions



Dimension drawing 7W-120-01

Connection types

Connection	IN / R
1	1/4" BSPP
2	7/16-20" UNF

Max. tightening torque BSPP

	IN / R
	1/4" BSPP
with steel washer	4.0 da/ Nm
with aluminium washer	3.0 da/ Nm
with cutting edge	4.0 da/ Nm

Max. tightening torque UNF

	IN / R
	7/16-20" UNF
with o- ring	2.0 da/ Nm

High- pressure adapters

High- pressure adapter ordering codes and specifications are shown in the PDF- file below:



High- pressure adapters: 7W-900-06

Fluids and materials

miniBOOSTER Hydraulics A/ S, Fynsgade 3, DK - 6400 Sønderborg, Tel: + 45 7442 9292
Please see: General specifications © 2016 COPYRIGHT MINIBOOSTER HYDRAULICS A/ S



Ordering an HC7W

Ordering example of an HC7W with $i = 13.0$, H1 M22 x 1.5 and H2 19/16-18 UNF.DV incorporated and BSPP connections:

HC7W - 13.0 - B - 12 for media $< 5 \text{ cSt (mm}^2/\text{s)}$ tested in water

HC7W - 13.0 - B - 12S for media $> 5 \text{ cSt (mm}^2/\text{s)}$ tested in hydraulic oil

Please note!

High- pressure adapter ordering code – see table

Model	Intensification, i	Dump valve	Connections		
HC7W	your selection... see flow rate table	your selection... A = (no) / A model B = (yes) / B model G = (proportional) / G model	see table below		
Ordering code	IN, R	H1	H2	H3	
HC7W- ___ - ___-11	1/4" BSPP	M22 x 1.5	–	–	
HC7W- ___ - ___-21	7/16-20 UNF	M22 x 1.5	–	–	
HC7W- ___ - ___-12	1/4" BSPP	M22 x 1.5	9/16-18 UNF	–	
HC7W- ___ - ___-22	7/16-20 UNF	M22 x 1.5	9/16-18 UNF	–	
HC7W- ___ - ___-13	1/4" BSPP	M22 x 1.5	9/16-18 UNF	9/16-18 UNF	
HC7W- ___ - ___-23	7/16-20 UNF	M22 x 1.5	9/16-18 UNF	9/16-18 UNF	