

**SPECIFICATIONS:**

MAX PRESSURE: 450 PSI  
CONTROL AIR PRESSURE: 50-120 PSI  
TEMPERATURE: 33-150 DEG F  
WEIGHT: 18 LBS  
FLUID DISCHARGE/CYCLE: 35 FL OZ. (.6L)  
TOTAL RESERVOIR VOLUME: 128 FL OZ. (2.1L)

**MATERIALS**

HEADS: ALUMINUM  
PRESSURE VESSEL: COMPOSITE  
VALVE: BRASS  
FLOAT: STAINLESS STEEL

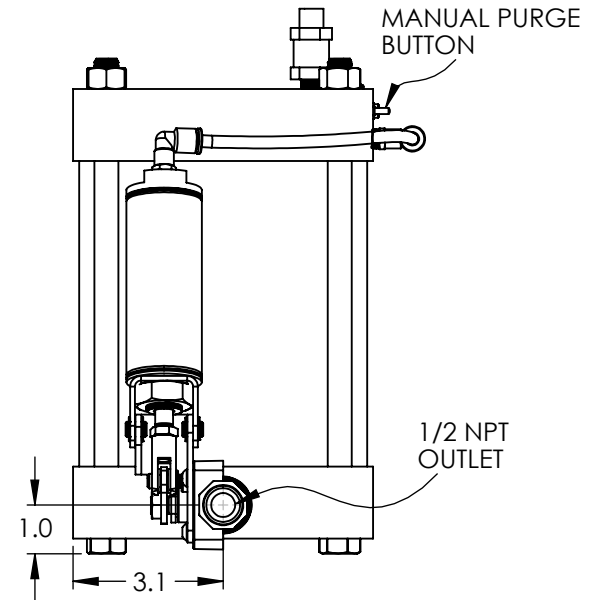
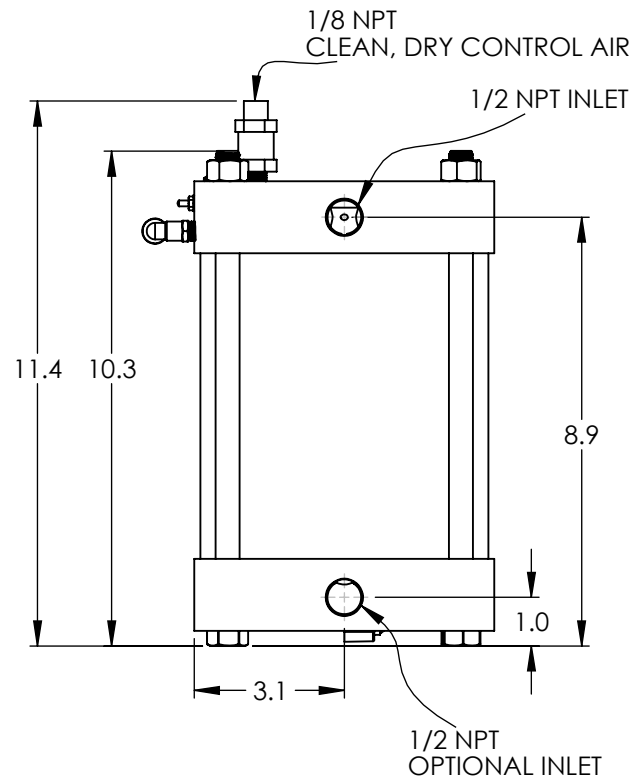
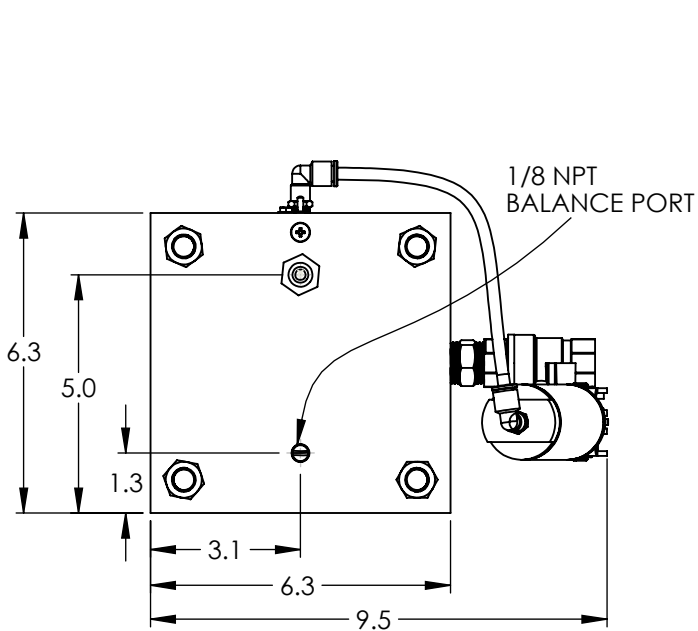
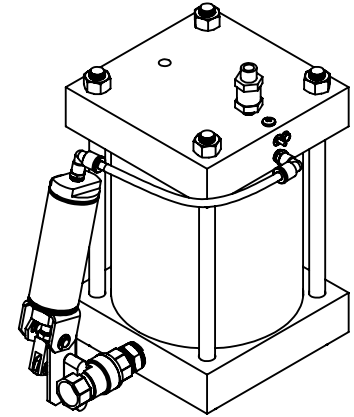

NOTE: ALL DIMENSIONS ARE IN INCHES UNLESS OTHERWISE NOTED

DRAWN BY: ALK DATE: 7/11/2024	AIR SYSTEM PRODUCTS www.airsyspro.com
TITLE: DEHYDRA, 450 PSI	
DWG.: PN-94102	REV. -